

REVISIONS			
REV.	DESCRIPTION	DATE	APPROVED

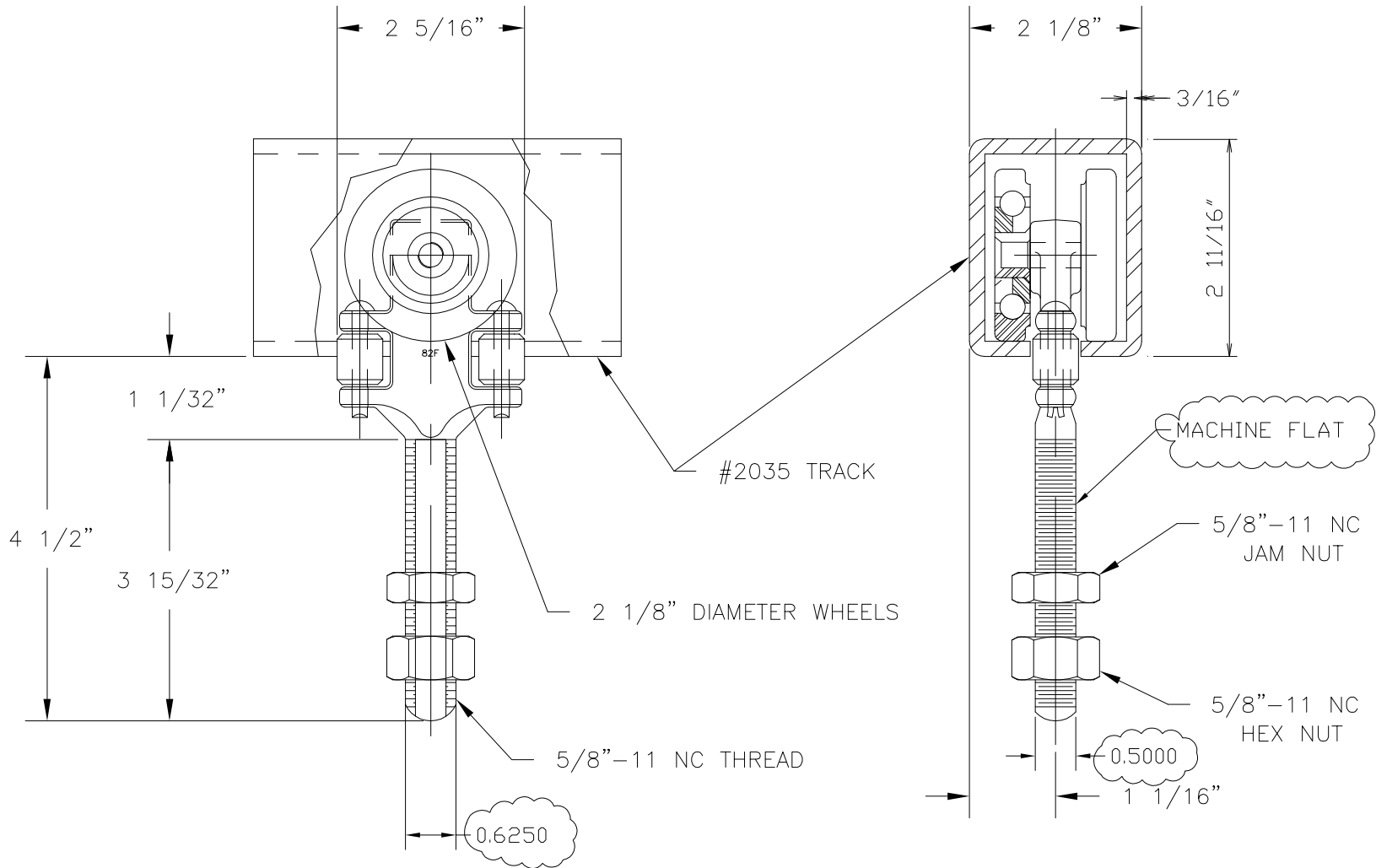

SPL. 2035.01976 TRUCK ASSEMBLY

300 EA. AS SHOWN

CUSTOM 2035.01976 BB TRUCK
 DWG #5B442
 DRAWN:BCM 2/12/07
 SCALE: 6" = 1'-0"
 SHEET # 1
 FILE:\hardware\5\spl 5 trolley

THE INFORMATION CONTAINED IN THIS DRAWING IS THE SOLE PROPERTY OF CROWN INDUSTRIAL. ANY REPRODUCTION IN PART OR AS A WHOLE WITHOUT WRITTEN PERMISSION OF CROWN INDUSTRIAL IS PROHIBITED.	PART #:	REV:
	DESCRIPTION:	
FINISH: ZINC PLTD	MATERIAL: STEEL	



CROWN INDUSTRIAL SUPPLY
 SO. SAN FRANCISCO, CA
 (650)952-5150